

For the operator

Operating instructions



ecoTEC plus

Gas-fired wall-hung high efficiency boiler

GB

Table of contents

Table of contents

1	Notes on the documentation	3	5	Energy saving tips	20
1.1	Document storage	3	6	Troubleshooting	22
1.2	Symbols used	3	6.1	Reading fault codes	23
1.3	Applicability of the instructions	3	6.2	Detecting and rectifying malfunctions	23
1.4	Identification plate	3	6.3	Rectifying a water shortage	24
1.5	CE label	3	6.4	Resolving ignition faults	24
2	Safety	4	6.5	Resolving faults in the air/exhaust gas pipework	25
2.1	Safety and warning information	4	7	Maintenance	25
2.1.1	Classification of warnings	4	7.1	Maintaining the boiler	25
2.1.2	Structure of warnings	4	7.2	Caring for your boiler	25
2.2	Intended Use	4	8	Decommissioning	26
2.3	General safety instructions	5	8.1	Disconnecting the boiler permanently	26
3	Equipment and functional description	7	8.1.1	Disposing of the boiler	26
3.1	Design	7	8.1.2	Disposing of the packaging	26
3.2	Function of the boiler	8	9	Manufacturer's guarantee and Vaillant customer service	26
3.2.1	Heating mode	8	9.1	Vaillant Service	26
3.2.2	Hot water production with DHW cylinder (VU unit)	8	9.2	Factory guarantee	26
3.2.3	Hot water production with VUW unit	8	10	Technical data	27
4	Operation	9	Glossary		32
4.1	Overview of control elements	9	Index		34
4.2	Display	10			
4.3	Preparing for start-up	11			
4.3.1	Opening the isolator devices	11			
4.3.2	Switching on the boiler	11			
4.3.3	Checking the fill level of the heating system	12			
4.3.4	Filling the heating system	12			
4.4	Setting the heating flow temperature	13			
4.4.1	Setting the heating flow temperature without a controller connected	13			
4.4.2	Setting the heating flow temperature with a controller	14			
4.5	Hot water production with VUW units	14			
4.5.1	Setting the hot water temperature	14			
4.5.2	Activating/deactivating comfort mode	14			
4.5.3	Setting storage tank charging (with actoSTOR)	16			
4.6	Hot water production with VU units	17			
4.6.1	Setting the hot water temperature	17			
4.7	Setting a room thermostat or weather compensator	17			
4.8	Switching the heating system off	18			
4.8.1	Switching hot water production off (VU unit)	18			
4.8.2	Switching heating mode off (summer mode)	18			
4.8.3	Temporarily taking the boiler out of service	18			
4.9	Protecting the heating system against frost	19			
4.9.1	Activating the frost protection function	19			
4.9.2	Draining the heating system	19			

1 Notes on the documentation

The following instructions are intended to guide you throughout the entire documentation. Other documents apply in addition to these operating instructions. We accept no liability for any damage caused by failure to observe these instructions.

Other applicable documents

When operating the ecoTEC plus, you must observe all operating instructions that are included with other components of your system.

These operating instructions are included with the individual components of the system.

1.1 Document storage

- Store these operating instructions and other applicable documents in such a way that they are available whenever required.
- If you move out or sell the appliance, pass on the documents to the relevant person as well.

1.2 Symbols used

The symbols used in the text are explained below.



Symbol that denotes danger,
 - Imminent danger to life
 - Danger of severe personal injury
 - Risk of minor personal injury



Symbol that denotes danger,
 - Danger of death from electric shock



Symbol that denotes danger,
 - Risk of material damage
 - Risk of damage to the environment



Symbol that denotes useful tips and information

- Symbol for a required action

1.3 Applicability of the instructions

These operating instructions apply exclusively to boilers with the following article numbers:

Unit	Type designation	Article number
ecoTEC plus	VU GB 126/5-5	0010011677
ecoTEC plus	VU GB 156/5-5	0010011678
ecoTEC plus	VU GB 186/5-5	0010011679
ecoTEC plus	VU GB 186/5-5 (LPG)	0010011680
ecoTEC plus	VU GB 246/5-5	0010011681
ecoTEC plus	VU GB 306/5-5	0010011682
ecoTEC plus	VU GB 306/5-5 (LPG)	0010011683
ecoTEC plus	VU GB 376/5-5	0010011684
ecoTEC plus	VUW GB 246/5-5	0010011685
ecoTEC plus	VUW GB 316/5-5	0010011686
ecoTEC plus	VUW GB 316/5-5 (LPG)	0010011687
ecoTEC plus	VUW GB 376/5-5	0010011688
ecoTEC plus	VUI GB 376/5-5	0010011691

Table 1.1 Type summary

To find out the article number of your boiler, refer to the identification plate.

1.4 Identification plate

The identification plate of your Vaillant ecoTEC plus boiler is attached at the factory to the bottom of your boiler.

The seventh to sixteenth digits of the serial number on the identification plate represent the article number.

1.5 CE label



CE labelling shows that the units comply with the basic requirements of the applicable directives as stated on the identification plate.



2 Safety

2.1 Safety and warning information

- When operating your boiler, take account of the general safety instructions and the warning notes that appear before each action.

2.1.1 Classification of warnings

The warning notes are classified in accordance with the severity of the possible danger using the following warning signs and signal words:

Warning signs	Signal word	Explanation
	Danger!	Immediate danger to life or risk of severe personal injury
	Danger!	Danger of death from electric shock
	Warning!	Risk of minor personal injury
	Caution!	Risk of material or environmental damage

Tab. 2.1 Meaning of danger signs and signal words

2.1.2 Structure of warnings

Warning signs are identified by an upper and lower separating line and are laid out according to the following basic principle:

	<p>Signal word!</p> <p>Type and source of danger!</p> <p>Explanation of the type and source of danger</p> <ul style="list-style-type: none"> ➤ Measures for averting the danger
---	--

2.2 Intended Use

The Vaillant ecoTEC plus boiler is a state-of-the-art appliance which has been constructed in accordance with recognised safety regulations. Nevertheless, there is still a risk of injury or death to the operator or others or of damage to the boiler and other property in the event of improper use or use for which it is not intended. The Vaillant ecoTEC plus boiler mentioned in these instructions must only be installed and operated in conjunction with the accessories mentioned in the corresponding installation instructions Air/exhaust gas pipework (→ **section 1.1**).

This boiler is not intended for use by persons (including children) having limited physical, sensory or mental capacities or who have inadequate experience and/or knowledge, unless supervised by a person responsible for their safety or who has been given instructions by them as to how to operate the boiler. Children must be supervised to ensure that they do not play with the boiler. The boiler is intended as a heater for closed hot water/central heating systems and for hot water production. Any other or additional use will be deemed as not in accordance with intended use. The manufacturer or supplier is not liable for any damage resulting from such use. The user alone bears the risk. Intended use also includes observance of the operating and installation instructions and the inspection/maintenance conditions.

2.3 General safety instructions

- Observe the following safety instructions at all times.

What to do in an emergency if you smell gas

Installation errors, damage, handling, unauthorised installation sites or similar can cause gas to escape and result in a risk of poisoning and explosion. If there is a smell of gas in the building, proceed as follows:

- Avoid rooms that smell of gas.
- Open all accessible doors and windows fully and ensure adequate ventilation.
- Avoid the use of naked flames (e.g. lighters, matches).
- Do not smoke.
- Do not use any electrical switches, mains plugs, doorbells, telephones or other communication systems in the building.
- Close the gas meter isolator device or the main isolator device.
- If possible, close the gas stop cock on the boiler.
- Warn other occupants in the building by knocking doors or calling out.
- Leave the building.
- If you can actually hear gas leaking, leave the building immediately and ensure that others do not enter the building.
- Alert the fire brigade and police when you are outside the building.
- Use a telephone outside the building to inform the emergency service department of the gas supply company.

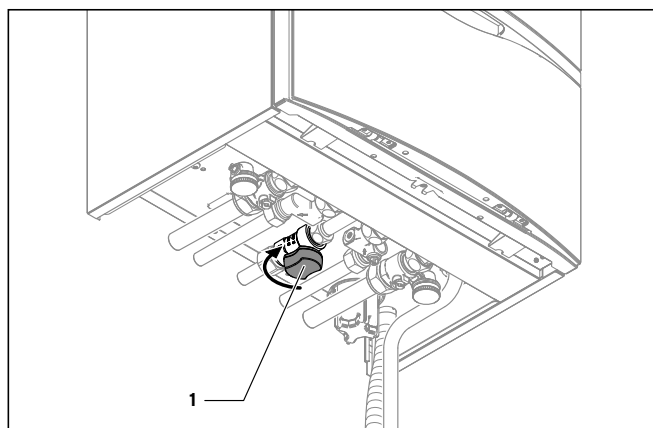

Fig. 2.1 Closing the gas stop cock

What to do in an emergency if you smell exhaust fumes

Installation errors, damage, handling, unauthorised installation sites or similar can cause exhaust fumes to escape and result in a risk of poisoning. If there is a smell of exhaust fumes in the building, proceed as follows:

- Open all accessible doors and windows fully and ensure adequate ventilation.
- Switch the boiler off.

Preventing the risk of explosion

The risk of explosion arises from the flammable mixture of gas and air. Take note of the following:

- Do not use or store explosive or highly flammable substances (such as petrol or paint) in the same room as the boiler.

Preventing scalding

There is a danger of scalding at the hot water draw-off points if the hot water temperatures are greater than 60 °C. Young children and elderly persons can be at risk at lower temperatures.

- Select the temperature so that nobody is at risk.

Preventing material damage due to unauthorised changes to the appliance.

Take note of the following:

- Never interfere or tamper with the boiler or other parts of the heating system.
 - Never try to carry out maintenance work or repairs on the boiler yourself.
 - Do not damage or remove any seals on components.
- Only suitably qualified heating engineers or our customer service may alter sealed components.

Material damage caused by corrosion

To prevent corrosion on the boiler and also on the exhaust system, note the following:

- Do not use any sprays, solvents, chlorinated cleaning agents, paint, adhesives or similar substances in the vicinity of the boiler.

Under unfavourable circumstances, these substances may cause corrosion.

2 Safety

Preventing frost damage

If there is a power cut, or if the room temperature is set too low in individual rooms, it cannot be ruled out that sections of the heating system might be damaged by frost.

- If you are going to be away during a cold period, make sure the heating system remains in operation and that the rooms are sufficiently heated.
- Always observe the information on frost protection provided in **section 4.9**.

Maintaining operation with an emergency power generator in the event of a power cut

Your heating engineer connected your boiler to the power mains during installation.

If the power supply is cut, it is possible that parts of the heating system may become damaged by frost.

If you want to maintain the operation of the boiler during a power cut using an emergency power generator, take note of the following:

- Make sure that the technical values of this generator (frequency, voltage, earthing) match those of the power mains.
- Contact your heating engineer for advice.

Changes to the surroundings of the boiler

A malfunction can result in a risk of poisoning and explosion.

- Never shut down the safety devices.
- Never tamper with the safety devices as this can prevent them from operating correctly.

A ban on modifications also applies to alterations to structural elements in the vicinity of the boiler which might affect its operational safety.

- Always contact an approved heating engineer to make modifications to the boiler or its surroundings.

Example: Enclosing the boiler in a cabinet requires that you observe special design instructions.

- Never enclose your boiler yourself.
- If you want to enclose the boiler in this way, you should ask your heating engineer.

What to do if there are leaks in the hot water pipes

Take note of the following:

- If there is a leak in the hot water pipes between the boiler and draw-off points, immediately turn off the cold water stop valve and have your heating engineer repair the leak.

With Vaillant ecoTEC plus boilers, the cold water stop valve is not included in the scope of supply of your boiler.

- Ask your heating engineer where he had fitted the cold water stop valve.

Preventing damage caused by low system pressure in the heating system

To prevent the heating system being used when the amount of water is too low and to therefore prevent any subsequent damage that may be caused by this, note the following:

- Check the filling pressure of the heating system at regular intervals.
- Always observe the information on frost protection provided in **section 4.3.4**.

Requirements for the installation site



It is not necessary to keep a clearance between the boiler and combustible materials or components, since at the nominal heat output of your boiler the temperature on the surface of the housing is always lower than the maximum permissible temperature of 85 °C.

3 Equipment and functional description

3.1 Design

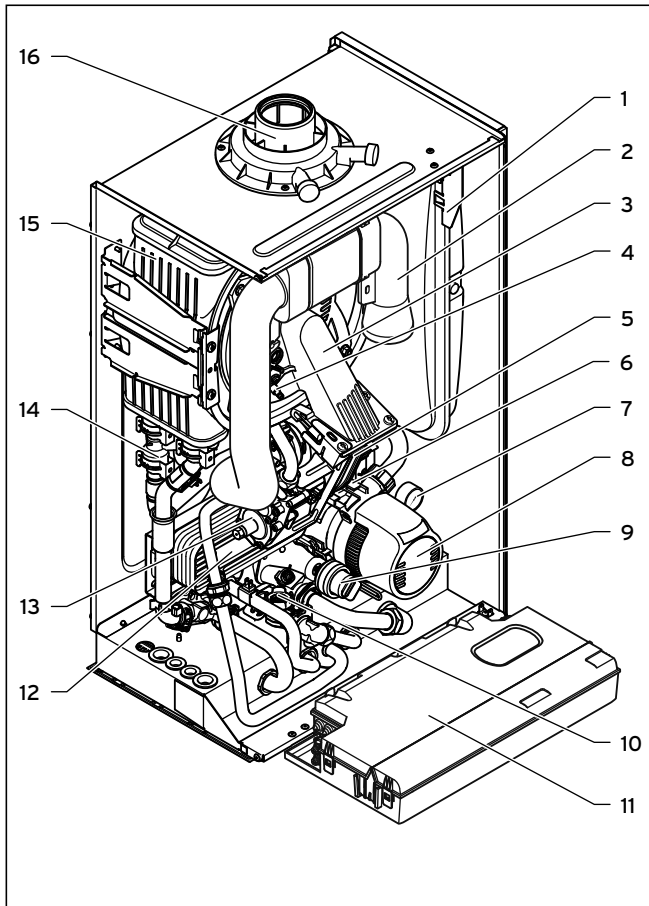

Fig. 3.1 Functional components VUW

Key

- 1 Diaphragm expansion tank
- 2 Air intake pipe
- 3 Compact thermal module
- 4 Ignition electrode
- 5 Fan
- 6 Automatic air vent
- 7 Pressure gauge
- 8 High-efficiency pump
- 9 Priority switching valve with by-pass
- 10 Fan sensor (hot water)
- 11 Electronics box
- 12 Secondary heat exchanger
- 13 Gas fitting
- 14 Water pressure sensor
- 15 Integral condensation heat exchanger
- 16 Connection for the air/exhaust gas pipework

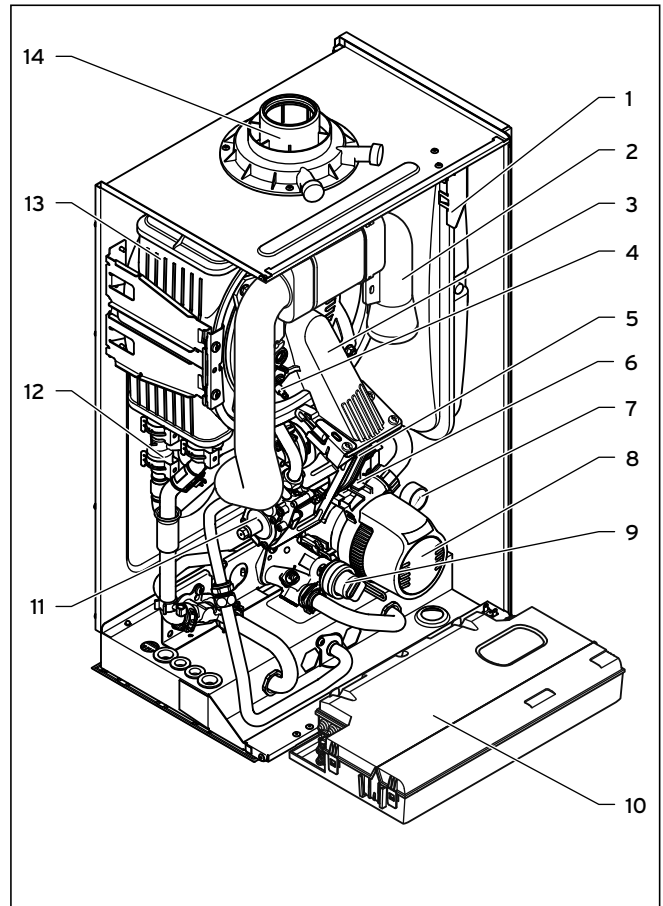

Fig. 3.2 Functional components VU

Key

- 1 Diaphragm expansion tank
- 2 Air intake pipe
- 3 Compact thermal module
- 4 Ignition electrode
- 5 Fan
- 6 Automatic air vent
- 7 Pressure gauge
- 8 High-efficiency pump
- 9 Priority switching valve with by-pass
- 10 Electronics box
- 11 Gas fitting
- 12 Water pressure sensor
- 13 Integral condensation heat exchanger
- 14 Connection for the air/exhaust gas pipework

3 Equipment and functional description

3.2 Function of the boiler

Your Vaillant ecoTEC plus boiler is a high-efficiency, gas-fired wall-hung boiler.

In addition to direct combustion heat, high-efficiency gas-fired wall-hung boilers also use the heat of condensation of the steam in the exhaust fumes. This makes them more efficient than traditional boilers. Furthermore, with condensing technology the exhaust gas temperatures are much lower than with conventional boilers, which reduces the heat lost via the exhaust fumes. In addition, the lower system temperatures of a heating system with high-efficiency technology reduce the losses from conduction of heat and radiation.

Your Vaillant ecoTEC plus boiler generates heat for heating and/or hot water production.

VU units can be operated together with a domestic hot water cylinder, which stores a larger volume of hot water.

VUW units are fitted with built-in hot water production.

3.2.1 Heating mode

In heating mode the boiler heats the hot water and pumps it through the radiators or underflooring heating of your home (heating circuit). The hot water pumped into the heating circuit exits the boiler at flow temperature, emits its heat into the rooms and flows back into the boiler once cooled to return temperature. The heating water is then heated again.

3.2.2 Hot water production with DHW cylinder (VU unit)

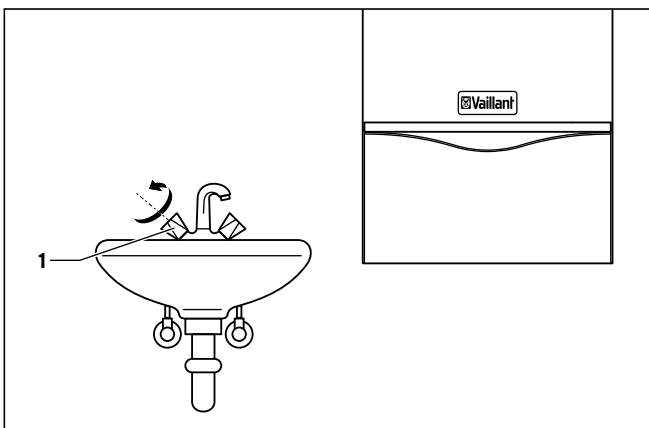

Fig. 3.3 Drawing off hot water

When you open a hot water tap (1) (sink, shower, bath, etc.), the hot water is taken from the domestic hot water cylinder.

Cold water then flows into the domestic hot water cylinder in its place. If the hot water temperature in the domestic hot water cylinder falls below the value set,

then the boiler operates automatically and reheats the domestic hot water cylinder. As soon as the water in the domestic hot water cylinder has received the set temperature, the boiler switches off. The heating pump in your boiler continues to run for a short time in order to supply the residual heat to the heating circuit.

3.2.3 Hot water production with VUW unit

When you open a hot water tap (1) (sink, shower, bath, etc.), the boiler operates automatically and supplies hot water.

When you close the hot water tap, the boiler automatically stops producing hot water.

The heating pump in your boiler continues to run for a short time in order to supply the residual heat to the heating circuit.

If you have activated comfort mode, the boiler immediately supplies you with hot water at the requested temperature without you having to wait for the water to heat up. For this, the hot water heat exchanger is kept at a preselected temperature level.



To prevent unnecessary energy loss, set the temperature selector not higher than the required temperature.

4 Operation

4.1 Overview of control elements

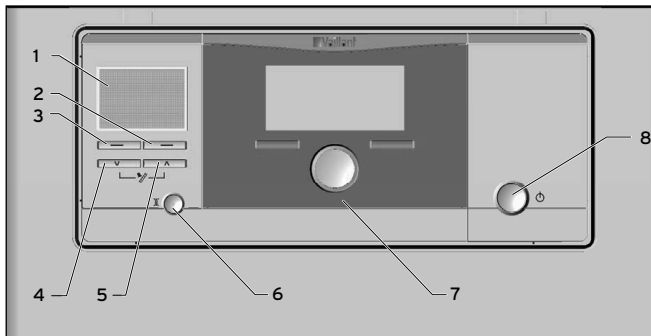





Fig. 4.1 Control elements ecoTEC plus

The control elements for your boiler are arranged behind the front flap.

To access the control elements, open the front flap as follows:

- Reach into the recessed grip in the front flap.
- Fold down the front flap.

Operation is controlled using the buttons with softkey function. For example, open the menu by pressing the selection button  under the "Menu" display. You can then navigate within the list of entries displayed using the "Scroll up"  and "Scroll down"  arrow keys.

With the selection buttons you can

- navigate to a lower or higher selection level,
- confirm a set value,
- cancel a change to a set value or
- activate an operating mode.

With the arrow keys you can

- navigate within the menu between the individual points on the list of entries or
- change a selected set value.

A highlighted object is indicated in the display inversely (light text on dark background).

When the end of the list of entries in a given selection level is reached, the marker jumps back to the first list entry.



If you do not press any buttons for more than 15 minutes, the display returns to the basic display. Changes that are not confirmed will not be applied.

The control elements are explained below.

- 1** Display for showing the current heating flow temperature, the fill pressure of the heating system, the operating mode or other information
- 2** "Operating mode" selection button to choose and call up information, e.g. heating and water temperature; to navigate to "Next"; to confirm set values
- 3** "Menu" selection button to
 - select and call up information
 - to navigate to a lower selection level within the list of entries
 - to cancel changes to set values
- 4** "Scroll down" arrow key to
 - decrease set values
 - Navigation to the next menu item
- 5** "Scroll up" arrow key to
 - increase set value
 - Navigation to the previous menu item
- 6** Reset button to clear certain faults
- 7** Controller (accessory)
- 8** On/Off button for switching the boiler on or off

4 Operation

4.2 Display

Digital Information and Analysis System (DIA)

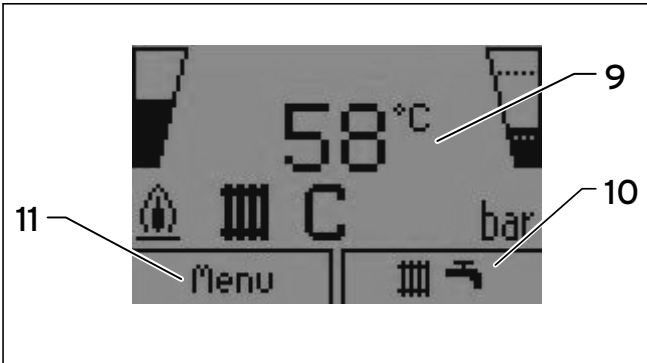

Fig. 4.2 Display ecoTEC plus

The ecoTEC plus boiler is fitted with a digital information and analysis system (DIA). This system provides information on the operating status of your boiler and helps you deal with problems.

When your boiler is in normal mode the display (1) shows the current heating flow temperature (in the example 58 °C) and the current fill pressure of the heating system in the bar graph display on the right. If a fault develops, a fault code appears instead of the temperature. The display of the ecoTEC plus also shows additional information in plain text.

- 9** Display of the present heating flow temperature of the heating system or fault code
- 10** Display of the current function of the right selection button (in the basic display, the setting of the heating and hot water temperature)
- 11** Display of the current function of the left selection button (in the "Menu" basic display)

You can also see the following information from the symbols displayed:



Heating mode active

permanently on: Heat requirement, heating mode

flashing: Burner on in heating mode (this function is used to frequently limit on/off operations and therefore contributes to increasing the life of your boiler)



Hot water production active

On VUW/APC units:
flashing: Burner on in draw-off mode

On VU units:
permanently on: window activated for hot water production

flashing: Domestic hot water cylinder is being heated, burner on



Display of the current fill pressure (bar graph display).
The fill pressure must be in the mid range between both dashed lines.



Display of the instantaneous burner modulation rate (bar graph display)



Flame without cross:
Burner operation normal



Flame with cross:
Fault during burner operation;
Unit is switched off



Only on VUW/APC units:
Comfort mode active

permanently on: Comfort mode is activated (activated by window)

flashing: Comfort mode is active, burner on



Burner blocking time active
This function is used to limit frequent on/off operations, and therefore contributes to prolonging the life of your boiler.

4.3 Preparing for start-up

4.3.1 Opening the isolator devices



The isolator devices are not included in the scope of supply of your boiler. The isolator devices are fitted by your heating engineer on site.

- He must explain to you the position and handling of these components.

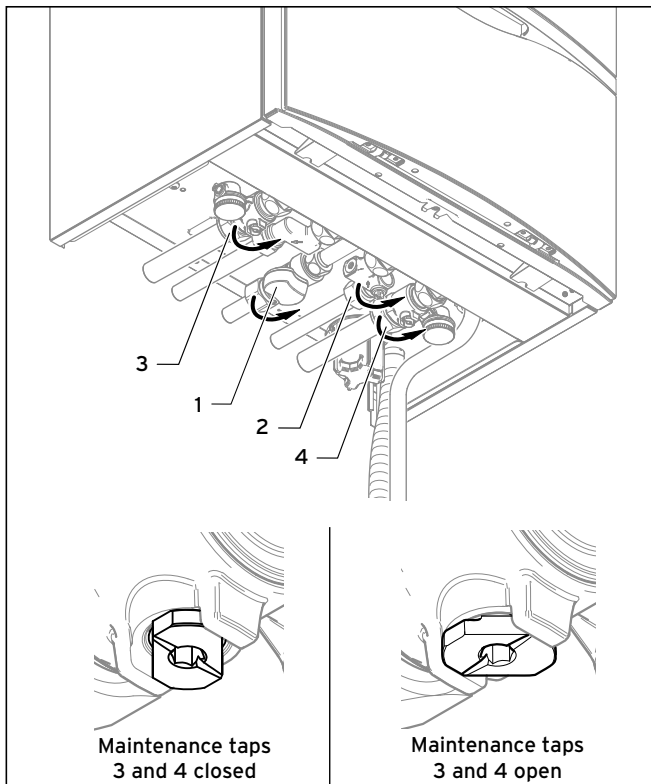

Fig. 4.3 Open isolator devices (shown using the example of service valves)

- Open the gas stop cock (1), by pushing the gas stop cock in and turning it anti-clockwise.
- Check that the heating flow (3) and heating return (4) service valves are open. This is the case if the notch in the square on the service valve matches the direction of the pipe.
If the service valves are closed, then you can open the service valves using an SW 4 Allen key by rotating a quarter turn anti-clockwise.

For unit type VUW:

- Open the cold water stop valve (2) by turning it anti-clockwise as far as it will go.

4.3.2 Switching on the boiler



Caution!

Material damage caused by frost!

Frost protection and monitoring devices are only active while the boiler is connected up to the power supply.

- Do not isolate the boiler from the power mains.
- Leave your boiler switched on at the on/off switch.

To ensure that the frost protection and monitoring devices remain active, switch your boiler on and off using the controller (see the corresponding operating instructions).

Section 8 describes how you can fully shutdown your boiler.

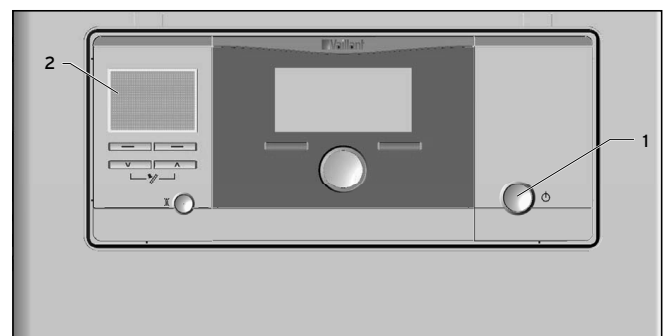

Fig. 4.4 Switching on the boiler

- Press the on/off switch (1) to switch on the boiler.

If the boiler is switched on, then the current heating flow temperature and other information will appear in the display (2) (Fig. 4.2).

To set your boiler to suit your needs, read **section 4.4** to **section 4.6** which describe the setting options for hot water production and heating mode.

4 Operation

4.3.3 Checking the fill level of the heating system



Caution!

Low fill pressure can cause damage to the unit!

Operating the heating system with low fill pressure can cause damage to the boiler and the heating system. The boiler switches off automatically when the fill pressure falls below 0.5 bar.

- Fill up the heating system as soon as the fill pressure falls below 0.8 bar.

To avoid operating the system with insufficient water and to prevent possible damage associated with this, your boiler is fitted with a pressure sensor. This signals the low pressure level if the level falls below 0.8 bar by the water pressure value in the display flashing.

- Fill up the heating system as soon as the pressure value in the display starts to flash.



If the fill pressure of the heating system falls below 0.5 bar, then the boiler switches off and the error message F.22 appears in the display. The heating system must be topped up with water before the boiler can be put into operation again.

The ecoTEC plus boiler has a digital pressure display. You can see the fill pressure in the right bar graph display or display the exact value using the selection buttons to the right of the display.

- Press the on/off switch (→ **Fig. 4.1, 8**) to switch on the boiler (→ **section 4.3.2**).
- Press the right "Operating mode" selection button  (heating/hot water).

The value of the flow temperature appears in the display. The right selection button is now assigned the "Next" function.

- Press the right selection button ("Next") until you reach the water pressure display.

The value of the fill pressure appears in the display.

To exit the water pressure display and return to the basic display:

- Press the "Next" or "Back" selection button until you have reached the desired level or the basic display.

If you do not press any buttons for more than 15 minutes, the display returns to the basic display.

If the heating system extends over several storeys, the system may require a higher filling pressure.

- Ask your heating engineer for details.

The filling pressure must lie between 1.0 and 2.0 bar when the heating system is cold in order for the heating system to operate properly. If the fill pressure falls below this range, then you must top it up with water before switching it on (→ **section 4.3.4**).

- Check the fill pressure of the heating system during start-up.

4.3.4 Filling the heating system



Caution!

Tap water that is extremely calciferous or corrosive or contaminated by chemicals can cause damage to the boiler!

Unsuitable tap water damages the seals and diaphragms, blocks components in the boiler and heating system through which the water flows and causes noise.

- Only fill the heating system with suitable tap water.
- In case of doubt, consult your heating engineer.

The filling pressure must be between 1.0 and 2.0 bar when the system is cold in order for the heating system to operate properly (→ **see section 4.3.3**).

- If the fill pressure is lower, then top it up with water.

If the heating system extends over several storeys, the system may require a higher filling pressure.

- Ask your approved heating engineer about this.

To fill up and to refill the heating system, you can normally use tap water. In exceptional cases, however, the water quality may not be suitable for filling the heating system because the water is highly corrosive or calciferous.

- If this is the case, contact your approved heating engineer.

The heating system is filled via a filling cock provided by the installer.

- Ask your heating engineer where the filling cock is located.
- Ask your heating engineer to explain how to fill the heating system.

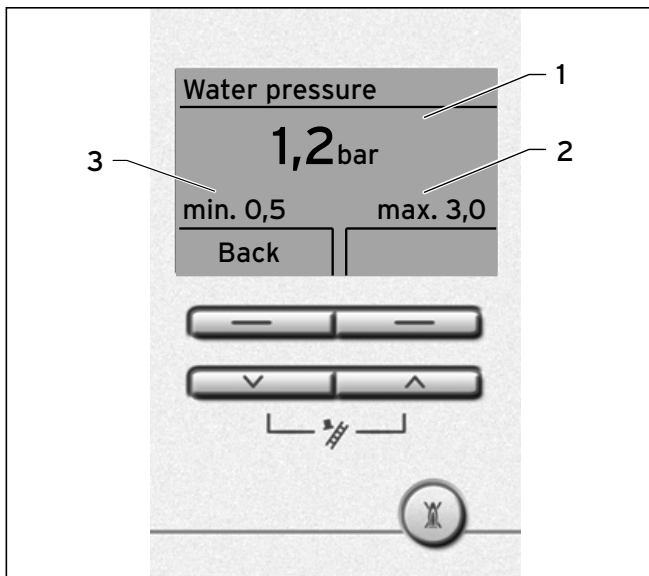





Fig. 4.5 Display Fill pressure

You can show the exact fill pressure in the display.

- Press the "Menu" selection button .

A selection of menu options appears in the display.

- Press the "Scroll down" arrow key  as far as the "Water pressure" menu option.
- Confirm by pressing the "Select" selection button .

The fill pressure (1) and the minimum (3) or maximum water pressure (2) appear in the display.

Proceed as follows to fill the heating system:

- Open all radiator valves (thermostatic radiator valves) of the heating system.
- Connect the filling cock for the heating system, as explained by your heating engineer, to a cold water draw-off valve.
- Open the filling cock slowly.
- Fill it with water until the required fill pressure is reached in the display.
- Close the draw-off valve.
- Bleed all the radiators.
- Then check the fill pressure on the display.
- Fill with more water if required.
- Close the filling cock.
- Press the "Next" or "Back" selection button until you have reached the desired level or the basic display.

If you do not press any buttons for more than 15 minutes, the display returns to the basic display.

4.4 Setting the heating flow temperature

4.4.1 Setting the heating flow temperature without a controller connected

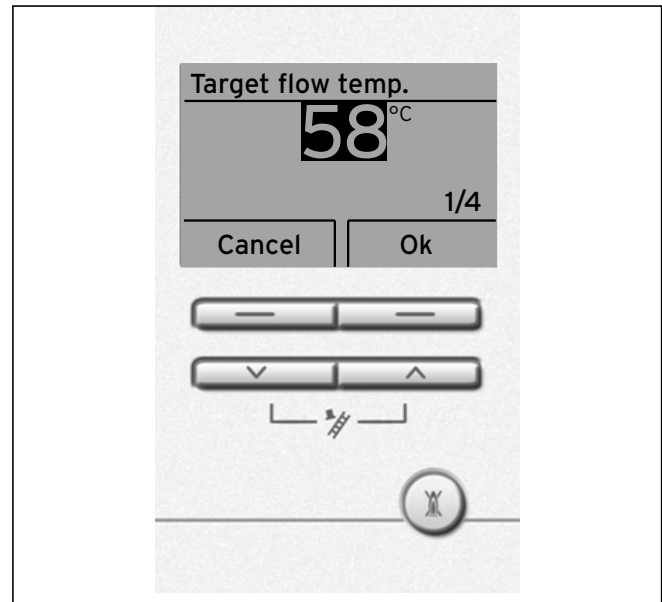





Fig. 4.6 Setting the heating flow temperature

If no external controller is fitted, then set the heating flow temperature according to the respective outside temperature as follows:

- Press the on/off switch to switch on the boiler.
- Press the "Operating Mode" selection button .

The value of the heating flow temperature appears in the display.

- Change the heating flow temperature using the "Scroll down"  or "Scroll up"  arrow keys.

The heating flow temperature is factory-set for temperatures up to 75 °C.

If higher (or lower) values can be set on your boiler, then your heating engineer has calibrated your unit to adjust the maximum temperature to your heating system.

- Confirm the change by pressing the "OK" selection button .

You have now set the heating flow temperature.

- Press the "Next" or "Back" selection button until you have reached the desired level or the basic display.

If you do not press any buttons for more than 15 minutes, the display returns to the basic display.

4 Operation

4.4.2 Setting the heating flow temperature with a controller

If your gas-fired wall-hung boiler has a room thermostat control system or weather compensator, make the following settings:

- Press the on/off switch to switch on the boiler.
- Set the maximum heating flow temperature (→ **section 4.4.1**).

The flow temperature is automatically adjusted by the controller (for information see the controller operating instructions).

4.5 Hot water production with VUW units

4.5.1 Setting the hot water temperature



Danger!
Risk of being scalded by hot water!

There is a danger of scalding at the hot water draw-off points if the hot water temperatures are greater than 60 °C. Young children and the elderly can even be at danger at lower temperatures.

- Select the temperature so that nobody is at risk.



Danger!
Possible danger to life from legionella!

If the unit is used to reheat water in a solar-based drinking water heating system, note the following:

- Set the minimum hot water temperature to 60 °C.



Caution!
Material damage due to calcification.

If the water hardness is more than -3.57 mol/m^3 (20 °dH), there is a risk of calcification.

- Set the maximum water temperature to 50 °C.

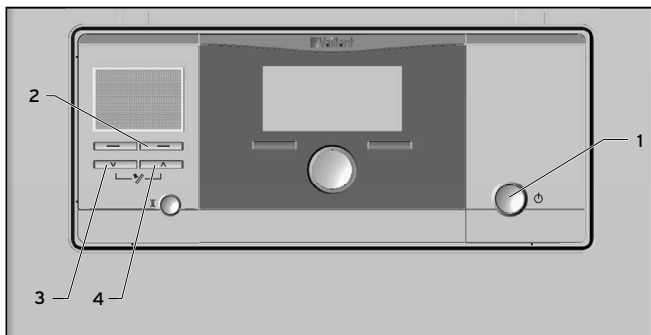



Fig. 4.7 Setting the hot water temperature

- Press the on/off switch (1) to switch on the boiler.
- Set the hot water temperature by pressing the following sequence of keys:
"Operating mode" selection button  --> "Next"

The hot water temperature is shown on the display.

- Change the hot water temperature with the "Scroll down" (3) or "Scroll up" (4) arrow keys.
- Confirm the changes by pressing the "OK" selection button (2).

The new hot water temperature is now set.

- Press the "Next" or "Back" selection button until you have reached the desired level or the basic display.

If you do not press any buttons for more than 15 minutes, the display returns to the basic display.

If your controller is connected to the boiler via a two-wire eBUS cable, then you can set the hot water target temperature on the controller.

Ask your approved heating engineer whether or not your controller is connected via a two-wire eBUS cable.

If your controller is connected via a two-wire eBUS:

- Set the hot water temperature on the boiler to the maximum possible temperature.
- Set the desired hot water temperature (hot water target temperature) on your controller.

4.5.2 Activating/deactivating comfort mode

Comfort mode immediately supplies you with hot water at the required temperature, without you having to wait for the water to heat up. To do this, the hot water heat exchanger of the ecoTEC plus is kept at your selected temperature level.

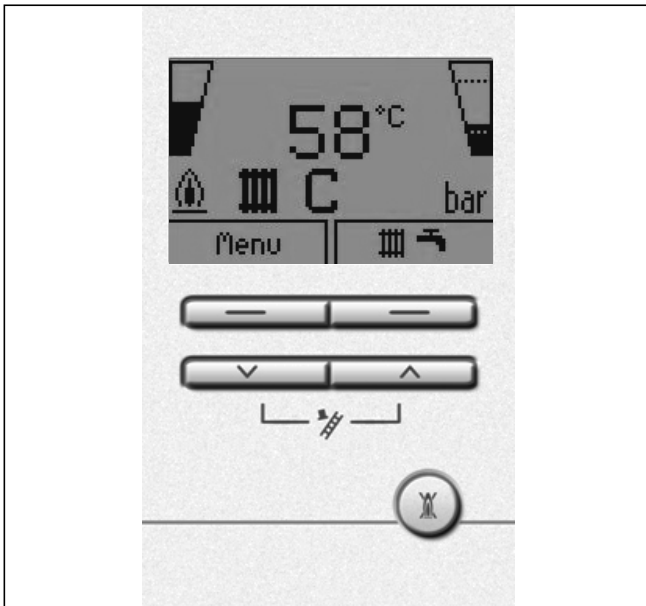





Fig. 4.8 Switching on/off the warm start function

Activate comfort mode by pressing the following sequence of keys:

"Operating mode" selection button  --> "Next" --> "Next"

"Comfort mode off" is shown on the display.

- Change "Comfort mode off" to "Comfort mode on" using the "Scroll down"  or "Scroll up"  arrow keys.
- Confirm the change by pressing the "OK" selection button .

Comfort mode is now set.

- Press the "Next" or "Back" selection button until you have reached the desired level or the basic display.

If you do not press any buttons for more than 15 minutes, the display returns to the basic display.



The C symbol appears on the basic display.

The unit automatically matches the hot start temperature to the set hot water temperature. The heated water is then immediately available when you draw it off.

Deactivate comfort mode by pressing the following sequence of keys:

"Operating mode" selection button  --> "Next" --> "Next"

"Comfort mode on" is shown on the display.

- Change "Comfort mode on" to "Comfort mode off" using the "Scroll down"  or "Scroll up"  arrow keys.
- Confirm the change by pressing the "OK" selection button .

Comfort mode is now off.

- Press the "Next" or "Back" selection button until you have reached the desired level or the basic display.

If you do not press any buttons for more than 15 minutes, the display returns to the basic display.

The symbol "C" disappears.

4 Operation

4.5.3 Setting storage tank charging (with actoSTOR)

In an additional stratified storage tank of the type actoSTOR VIH CL 20 S is connected you can switch cylinder charging on and off using the controller on your gas-fired wall-hung boiler. Cylinder charging refers to the process for heating up the cylinder.



Cylinder charging is deactivated ex-works and must be activated during initial start-up.

Cylinder charging of the layer storage tank is only active if comfort mode is switched on. This is shown by the symbol "C" in the display (→ see section 4.5.2).

When the cylinder charging function is switched on, the following temperatures can be set for the hot water temperature (→ section 4.5.1):

- **minimum temperature** **50 °C**
- **maximum temperature** **65 °C**

When the cylinder charging function is switched off, the following temperatures can be set for the hot water temperature (→ section 4.5.1):

- **minimum temperature** **35 °C**
- **maximum temperature** **65 °C**

If the cylinder charging function is switched off the storage tank is not held at temperature. In this case the unit switches on when water is drawn off and operates on a through-flow principle.



Danger! **Risk of scalding!**

The units are fitted with an automatic legionella protection control: If the temperature in the hot water domestic hot water cylinder falls below 50 °C, the cylinder is heated up to 70 °C once every 24 hours.

- If this is the case, try not to draw off any water.



Your heating engineer can switch off the legionella protection function. Ask your heating engineer for details.

Switching on cylinder charging

➤ Press the on/off switch to switch on the boiler. Switch on cylinder charging by pressing the following sequence of keys:

- "Operating mode" selection button  --> "Next" --> "Next"

"Comfort mode off" is shown on the display.

- Change "Comfort mode off" to "Comfort mode on" using the "Scroll down"  or "Scroll up"  arrow keys.
- Confirm the change by pressing the "OK" selection button .

Cylinder charging is now set.

- Press the "Next" or "Back" selection button until you have reached the desired level or the basic display.

If you do not press any buttons for more than 15 minutes, the display returns to the basic display.

The "C" symbol appears on the basic display.



- Set the cylinder temperature using the hot water temperature setting (→ section 4.5.1).

Switching off cylinder charging

Switch off cylinder charging by pressing the following sequence of keys:

- "Operating mode" selection button  --> "Next" --> "Next"

"Comfort mode on" is shown on the display.

- Change "Comfort mode on" to "Comfort mode off" using the "Scroll down"  or "Scroll up"  arrow keys.
- Confirm the change by pressing the "OK" selection button .

Cylinder charging is now off.

- Press the "Next" or "Back" selection button until you have reached the desired level or the basic display.

If you do not press any buttons for more than 15 minutes, the display returns to the basic display.

The symbol "C" disappears.

The unit now operates in the through-flow principle, the cylinder is not held at temperature.

4.6 Hot water production with VU units

4.6.1 Setting the hot water temperature



Danger!
Risk of being scalded by hot water!

There is a danger of scalding at the hot water draw-off points if the temperatures are greater than 60 °C. Young children and elderly persons can be at risk at lower temperatures.

- Select the temperature so that nobody is at risk.



Danger!
Possible danger to life from legionella formation.

In domestic hot water cylinders there is a risk of legionella forming, which can cause illness.

- If the unit is used for post-heating within a solar-supported drinking water heating installation, set the hot water outlet temperature to at least 60 °C.



Caution!
Material damage due to calcification.

If the water hardness is more than -3.57 mol/m^3 (20 °dH), there is a risk of calcification.

- Set the maximum water temperature to 50 °C.

To produce hot water in conjunction with the VU unit type a VIH-type domestic hot water cylinder must be connected to the boiler.

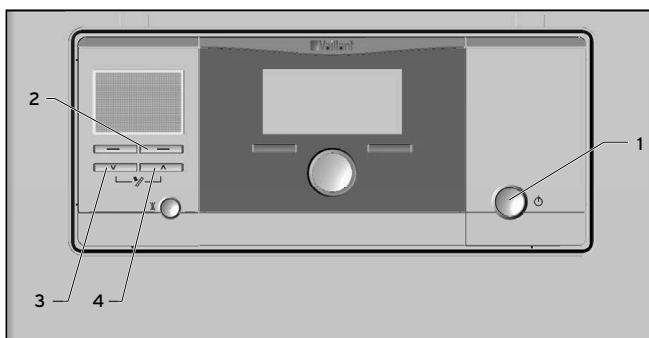

Fig. 4.9 Setting the hot water temperature

- Press the on/off switch (1) to switch on the boiler.
- Set the hot water temperature by pressing the following sequence of keys:
"Operating mode" (2) selection button --> "Next"

The hot water temperature is shown on the display.

- Change the hot water temperature with the "Scroll down" (3) or "Scroll up" (4) arrow keys.
- Confirm the changes by pressing the "OK" selection button (2).

The new hot water temperature is now set.

- Press the "Next" or "Back" selection button until you have reached the desired level or the basic display.

If you do not press any buttons for more than 15 minutes, the display returns to the basic display.

If your controller is connected to the boiler via a two-wire eBUS cable, then you can set the hot water target temperature on the controller.

Ask your approved heating engineer whether or not your controller is connected via a two-wire eBUS cable.

If your controller is connected via a two-wire eBUS

- Set the hot water temperature on the boiler to the maximum possible temperature.
- Set the desired hot water temperature (hot water target temperature) on your controller.

4.7 Setting a room thermostat or weather compensator

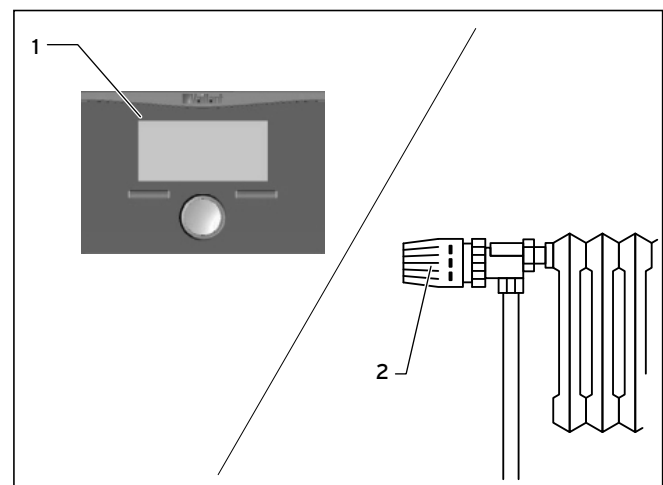

Fig. 4.10 Setting a room thermostat or weather compensator

- Set the room thermostat, weather compensator (1) and thermostatic radiator valves (2) as specified in the operating instructions for these accessories.

4 Operation



4.8 Switching the heating system off

4.8.1 Switching hot water production off (VU unit)

You can switch off cylinder charging without switching off heating mode.

- Set the lowest possible hot water temperature by pressing the following sequence of keys:
"Operating mode" selection button  --> "Next"

The hot water temperature is shown on the display.

- Change the hot water temperature to the lowest value 30 °C with the "Scroll down"  arrow key.
- Confirm the change by pressing the "OK" selection button .

Cylinder charging is switched off. Only the frost protection function for the cylinder remains active.

4.8.2 Switching heating mode off (summer mode)

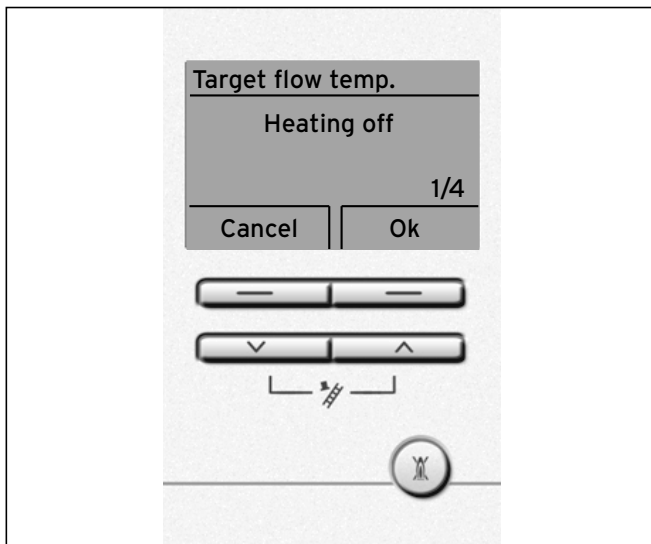



Fig. 4.11 Switching off heating mode (summer operation)

You can switch off the heating mode in summer without switching off the hot water supply.

- Set the heating flow temperature to "Heating off" with the "Scroll down"  arrow key.
- Confirm the change by pressing the "OK" selection button .

Heating mode is switched off.

4.8.3 Temporarily taking the boiler out of service



Caution!

Material damage caused by frost!

Frost protection and monitoring devices are only active while the boiler is connected up to the power mains and the on/off switch is on.

- Do not isolate the boiler from the power mains.
- Leave your boiler switched on at the on/off switch.
- Only switch the boiler on and off in normal mode using the controller.
- Make sure that the boiler cannot become damaged by frost.

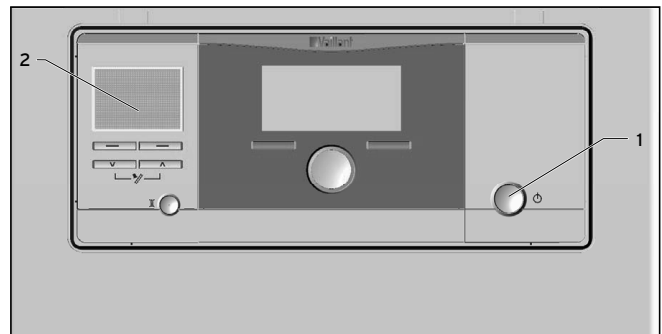

Fig. 4.12 Switching off the boiler

- Press the on/off switch (1) to switch off the boiler.

If the boiler is switched off, the display (2) turns off.



If the boiler is going to be unused for longer periods (e.g. holiday), you should also close the gas stop cock and the cold water stop valve, but only if there is no risk of frost.



The isolator devices are not included in the scope of supply of your boiler. These are installed are fitted by your heating engineer on site.

- Ask your heating engineer to explain to you the position and handling of these isolator devices.

4.9 Protecting the heating system against frost



Caution!

Material damage caused by frost!

Frost protection and monitoring devices are only active while the boiler is connected up to the power mains and the on/off switch is on.

- Do not isolate the boiler from the power mains.
- Leave your boiler switched on at the on/off switch.



Caution!

Tap water that is extremely calciferous or corrosive or contaminated by chemicals can cause damage to the boiler!

Unsuitable tap water damages the seals and diaphragms, blocks components in the boiler and heating system through which the water flows and causes noise.

- Only fill the heating system with suitable tap water.
- In case of doubt, consult your approved heating engineer.

The heating system and water pipes are sufficiently protected against frost if the heating system remains on and the rooms are sufficiently heated while you are away.

4.9.1 Activating the frost protection function

Your Vaillant ecoTEC plus boiler is fitted with a frost protection function:

If the heating flow temperature falls below 5 °C when the main switch is on, the boiler comes into operation and heats the heat generation circuit to approx. 30 °C.



Caution!

Material damage caused by frost!

The frost protection function cannot guarantee flow through the entire heating system, which means that parts of the heating system may freeze and become damaged.

- Make sure that the boiler remains on whilst you are away.
- Make sure that the rooms are heated sufficiently.

4.9.2 Draining the heating system

Another way to protect the heating system and the boiler from frost is to drain them. You must ensure that the heating system and boiler are completely drained. All the cold and hot water pipes in the house and in the boiler must also be drained.

- Ask your heating engineer to drain the heating system.

5 Energy saving tips

5 Energy saving tips

Installation of a weather compensator

Weather compensators regulate the heating flow temperature with reference to the outside temperature. No more heat is generated than is currently required. The designated heating flow temperature for the corresponding outside temperature must be set on the weather compensator. This setting must not be greater than that required by the design of the heating system. The correct setting is normally undertaken by the heating engineer. The required heating and setback phases (e.g. at night) are automatically switched on/off using integrated timer programmes. Weather compensators combined with thermostatic radiator valves are the most economical form of heating regulation.

Energy-saving mode of the heating system

Reduce the room temperature at night and in your absence. This is most easily and reliably achieved using controllers with timer programmes that can be selected according to individual requirements. At such times, set the room temperature approx. 5 °C lower than during full heating times. Reduction of more than 5 °C brings no additional energy saving, because then increased heating capacities would be needed for the next full heating period. Only for longer absences, e.g. holidays, is it worthwhile to further lower the temperatures. However, in winter, make sure that there is adequate frost protection.

Room temperature

Set the room temperature only as high as would be enough for your comfort level. Each extra degree would mean an increased energy consumption of about 6%. Adjust the room temperature according to the use of the specific room. For example, normally, bedrooms or seldom used rooms are heated to 20 °C.

Setting the operating mode

In warmer seasons, when the apartment needs no heating, turn the heating to summer mode. The heating mode is then shut off; however, the boiler or the heating system remains ready for operation for hot water production.

Uniform heating

Often, in an apartment with central heating, only one room is heated. Adjacent rooms are also heated without regulation by the enclosing surfaces of the room, i.e. walls, doors, windows, roofs and floors, which means that an unwanted loss of thermal energy occurs. In these kind of operating conditions the power of the radiator in this heated room is obviously insufficient. Consequently, the room cannot be heated adequately and an uncomfortable feeling of coolness prevails (the same effect is produced when doors between heated and unheated or partially heated rooms remain open).

This is false economy: The heating is in operation and still the room temperature is not comfortably warm. Greater heating comfort and a more practical operating mode is achieved when all rooms in an apartment are heated uniformly and in accordance to their usage. The building structure can also suffer if components of the building are unheated or only inadequately heated.

Thermostatic radiator valves and room thermostats

Nowadays, all radiators should be fitted with thermostatic radiator valves as a matter of course. They maintain the set room temperature precisely. You can adjust the room temperature to suit your individual requirements and ensure effective operation of your heating system using thermostatic radiator valves in combination with a room thermostat (or weather compensator). In the room where the room thermostat is located, all the radiator valves should be fully opened, as otherwise the two regulating systems will work against each other and the regulation quality can be affected. And besides, the following user behaviour can frequently be observed: As soon as the room becomes too hot the operator turns the thermostatic radiator valve off (or specifies a lower temperature at the room thermostat). If after a period of time the user feels cold and opens the thermostatic radiator valve again. This procedure is not only inconvenient, it is also completely unnecessary as a correctly functioning thermostatic valve does this automatically: If the room temperature rises above the value set on the sensor head, the thermostatic radiator valve shuts off automatically, when the temperature drops below the defined value, it opens again.

Do not cover controllers

Do not cover your controllers with furniture, drapes or similar objects. The room air must circulate unhindered. Covered thermostatic radiator valves can be equipped with remote sensors and thus still work.

Ventilating residential spaces

During the heating period, open windows only for ventilation and not for temperature regulation. A brief, forced change of air is more effective and energy-saving than windows that are kept open for a long time. We recommend that the windows be opened fully for a short period. During ventilation, close all thermostatic radiator valves in the room or set the room thermostat to minimum temperature. These measures guarantee a sufficient exchange of air and avoid unnecessary cooling and loss of energy (e.g. due to unwanted activation of the heating system during ventilation).

Appropriate hot water temperature

Anyone wanting to wash their hands under warm water does not want to have their fingers scalded. The following applies both for boilers with integral hot water production and for boilers with hot water cylinders connected: The warm water should only be heated up to

the extent that is necessary for use. Any further heating results in unnecessary power consumption and hot water temperatures of more than 60 °C also lead to increased lime scale reduction.

Switching on comfort mode (only VUW):

Comfort mode immediately supplies you with hot water at the required temperature, without you having to wait for the water to heat up. For this, the hot water heat exchanger is kept at a preselected temperature level. To prevent energy loss, set the temperature selector not higher than the required temperature. If you do not need hot water for a long period, it is recommended to turn off comfort mode to save energy further.

Energy-conscious use of water

Energy-conscious use of water can also reduce costs considerably, e.g. taking showers instead of baths: whereas about 150 litres of water are required for a bath, a modern shower equipped with water saving fittings only requires a third of this water quantity. By the way: a dripping water tap wastes up to 2,000 litres of water and a leaking toilet flush up to 4,000 litres of water each year. On the other hand, a new seal only costs a few cents.

Run circulation pumps only if needed

Circulation pumps facilitate the continuous circulation of hot water through the piping system which means that hot water is immediately available, also at more distant draw-off points. These pumps undoubtedly enhance the convenience of the hot water production process. But they also need power. And circulating hot water that is not used cools off when passing through pipes and then needs to be reheated. Therefore, circulation pumps are to be operated only when hot water is actually needed for the household. Individual timer programmes can be defined using switching clocks, which are already installed or can be retrofitted in most circulation pumps. Weather compensators often have ancillary functions for controlling circulation pump timings. Consult your heating engineer. Another option is to turn on the circulation only for concrete needs for a specific period of time by using a button or switch installed near a frequently used draw-off point. A corresponding button can be connected to the Vaillant ecoTEC plus boiler electronics.

6 Troubleshooting

6 Troubleshooting



Danger!
Danger of injury and material damage due to incorrect maintenance and repairs!

If maintenance is not carried out, or carried out incorrectly, this may adversely affect the operating reliability of your boiler.

- Never attempt to perform maintenance or repairs on your boiler by yourself.
- Always employ an approved heating engineer.

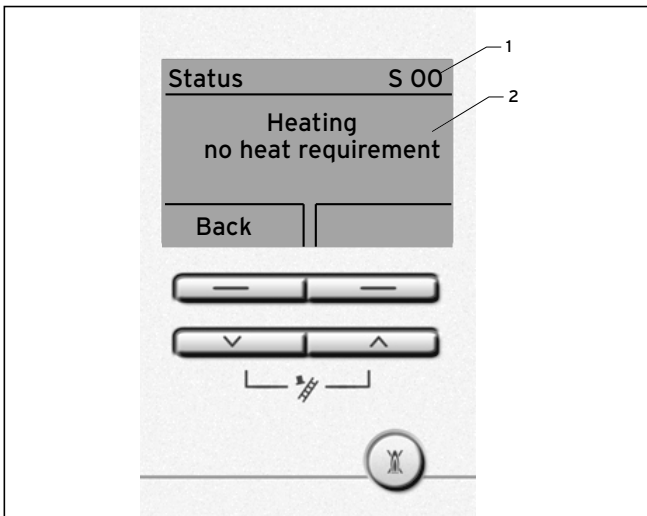

Fig. 6.1 Live Monitor

The Live Monitor provides information on the operating status of your boiler.

- Press the "Menu" selection button

A selection of menu options appears in the display.

- Press the "Scroll down" arrow key
- Confirm by pressing the "Select" selection button

The current status of the boiler appears in the display (1), which is explained by additional plain text (2) in the display.

The following table explains the most important status codes.

- Press the "Back" selection button until you have reached the desired level or the basic display.

If you do not press any buttons for more than 15 minutes, the display returns to the basic display.

Display	Meaning
	Displays in heating mode
S 00	Heating no heat demand
S 02	Heating mode pump pre-run
S 03	Heating mode ignition
S 04	Heating mode burner on
S 06	Heating mode fan overrun
S 07	Heating mode pump overrun
S 08	Heating, remaining cut-off time xx min
S 31	No heat demand, summer operating mode
S 34	Heating mode, frost protection
	Displays in hot water handling mode (VUW unit)
S 10	Hot water demand via fan sensor
S 14	Hot water handling mode burner on
	Displays in storage tank charging
S 20	Hot water demand
S 22	Hot water handling mode pump pre-run

Tab. 6.1 Status codes and what they mean (selection)

6.1 Reading fault codes

If a fault develops in the boiler, the display shows a fault code starting with "F...".

A plain text display explains the displayed fault code.

Example for F.10: "Short circuit heating feed sensor".

Fault codes have priority over all other displays. If a fault occurs, then the display no longer shows the current heating flow temperature.

If multiple faults occur at the same time, then the display shows the corresponding fault codes for two seconds each in sequence.

- If your boiler displays a fault code, then contact your heating engineer.

6.2 Detecting and rectifying malfunctions

If problems occur whilst operating your boiler, you can carry out the following self-checks:

Problem	Possible cause	Solution
No hot water, heating stays cold; Boiler does not start	Building gas stop cock closed	Open building gas stop cock (→ section 4.3.1)
	Building power supply switched off	Switch on building power supply
	Mains switch on boiler switched off	Switch on mains switch on boiler (→ section 4.3.2)
	The heating flow temperature is set too low or in the "Heating off" position (→ section 4.8.2) and/or the hot water temperature is too low	Set the heating flow temperature to the desired temperature (→ section 4.4) and/or set the hot water temperature to the desired temperature (→ section 4.5 and 4.6)
	Fill pressure of the heating system too low	Top up the heating system with water (→ section 4.3.4)
	Air in the heating system	Bleed the radiators; If the problem occurs again: Contact your heating engineer
	Ignition malfunction	Press the reset button; If the problem occurs again: Contact your heating engineer (→ section 6.4)
Hot water handling, no problem; Heating does not start:	No heating demand via the controller	Check the timer programme on the controller and correct if necessary; Check the room temperature and correct the target room temperature if necessary (→ section 4.7; Controller operating instructions)

Tab. 6.2 Detecting and rectifying malfunctions

- If after checking the points mentioned in **Tab. 6.2** your boiler still shows signs of a fault, contact your heating engineer to troubleshoot the problem.

Troubleshooting 6

6.3 Rectifying a water shortage



Caution!

Tap water that is extremely calciferous or corrosive or contaminated by chemicals can cause material damage!

Unsuitable tap water damages the seals and diaphragms, blocks components in the boiler and heating system through which the water flows and causes noise.

- Only fill the heating system with suitable tap water.
- In case of doubt, consult your approved heating engineer.

As soon as the fill pressure falls below a limit, the service message "Check water pressure" appears in the display.

The filling pressure must be between 1.0 bar and 2.0 bar when the system is cold in order for the heating system to operate properly (→ see section 4.3.3).

- If the fill pressure is lower, then top it up with water (→ section 4.3.4).

As soon as the system has been topped up with sufficient water, the message disappears automatically after approx. 20 seconds.

If the system falls below a pressure of 0.5 bar, the boiler will switch off. The error message "F.22" appears in the display. The system must be topped up with water before the unit can be put into operation again. If the pressure drops frequently the reason for the loss of hot water must be identified and eliminated

- Contact your heating engineer.

If the heating system extends over several storeys, the system may require a higher filling pressure.

- Ask your approved heating engineer about this.

To fill up and to refill the heating system, you can normally use tap water. In exceptional cases, however, the water quality may not be suitable for filling the heating system because the water is highly corrosive or calciferous.

- If this is the case, contact your approved heating engineer.

6.4 Resolving ignition faults



Caution!

Risk of damage due to improper alterations! Improper alterations or persistent faults can result in material damage.

- If you are unable to resolve the ignition problem yourself by resetting the boiler three times, then consult your heating engineer.

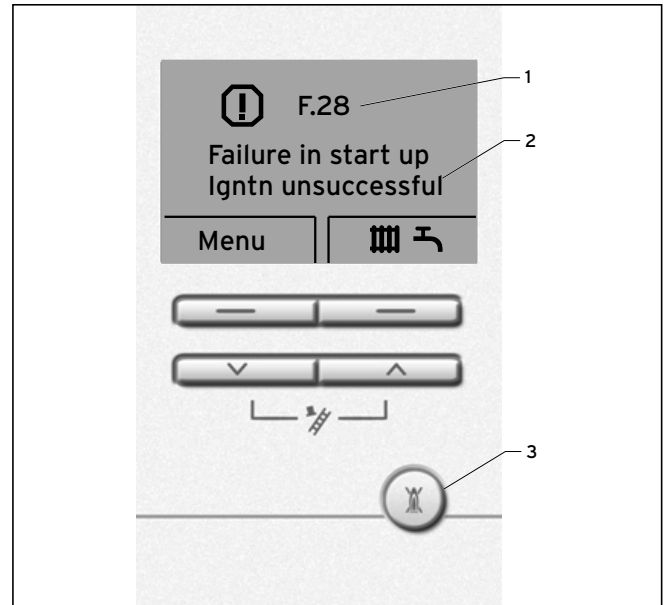

Fig. 6.2 Troubleshooting

If the burner fails to ignite after five attempts, the boiler will not operate and switches to "Fault". This is indicated by the fault code "F.28" or "F.29" (1) on the display.

On Vaillant ecoTEC plus boilers, a struck through flame symbol is also displayed along with the relevant plain text in the display, e. g. for F.28: "Failure during starting, ignition unsuccessful" (2).

The boiler will only ignite automatically again once you have reset it manually.

- To reset the boiler manually, press the reset button (3) and hold for one second.

6.5 Resolving faults in the air/exhaust gas pipework



Danger!
Risk of injury and material damage resulting from improper modifications!

Improper alterations can affect the operating safety of your boiler.

- Never attempt to perform repairs on your boiler by yourself.
- Always employ a recognised heating engineer.

The boilers are fitted with a blower. If the blower does not work properly, the boiler will switch itself off. The error message "F.32" appears in the display. The displayed fault code is additionally explained by a corresponding plain text message in the display: "Blower fault".

7 Maintenance



Danger!
Danger of injury and material damage due to incorrect maintenance and repairs!

If maintenance is not carried out, or carried out incorrectly, this may adversely affect the operating reliability of your boiler.

- Never attempt to perform maintenance work or repairs on your water boiler by yourself.
- Always employ a recognised heating engineer.

7.1 Maintaining the boiler

Permanent operational readiness and safety, reliability and a long working life require inspections and maintenance work to be carried out annually on the boiler by a heating engineer.

Regular servicing ensures maximum efficiency and economical operation of your boiler.

We recommend making a maintenance agreement.

7.2 Caring for your boiler



Caution!
Unsuitable cleaning agents can cause damage!

Unsuitable cleaning agents (scouring or other cleaning agents) can damage the exterior, the fittings or the control elements.

- Do not use sprays, solvents or cleaning agents containing chlorine.

- Clean the exterior of your boiler with a damp cloth and a little soap.

8 Decommissioning

9 Manufacturer's guarantee and Vaillant customer service

8 Decommissioning

8.1 Disconnecting the boiler permanently

- Contact a heating engineer to disconnect the boiler permanently.

8.1.1 Disposing of the boiler

Do not dispose of your Vaillant ecoTEC plus boiler or any of its accessories in the household waste.

- Make sure the old unit and any accessories are disposed of properly.
- Observe national regulations.

8.1.2 Disposing of the packaging

Arrange for the approved heating engineer who installed the boiler to dispose of the transport packaging.

9 Manufacturer's guarantee and Vaillant customer service

9.1 Vaillant Service

To ensure regular servicing, it is strongly recommended that arrangements are made for a Maintenance Agreement. Please contact Vaillant Service Solutions (0870 6060 777) for further details.

9.2 Factory guarantee

Two year guarantee for ecoTEC plus appliances

Vaillant undertakes to rectify any manufacturing defect that occurs within twenty-four months of the installation date.

For the 2nd year of the guarantee to be valid an annual service must be carried out by a competent person approved at the time by the Health and Safety Executive one year after installation.

The cost of this annual service is not included in the guarantee.

Registering with us

Registration is simple. Just complete the Guarantee Registration Card and return to Vaillant within 30 days of installation. Your details will then be automatically registered within the Vaillant scheme.

Note: No receipt will be issued.

Immediate help

If your Vaillant boiler develops a fault your first action should be to contact your installer, as his professional assessment is needed under the terms of our Guarantee. If you are unable to contact your installer, phone Vaillant 0870 6060 777

10 Technical data

ecoTEC plus	Unit	VU GB 126/5-5	VU GB 156/5-5	VU GB 186/5-5	VU GB 246/5-5	VU GB 306/5-5	VU GB 376/5-5	
Nominal heat output range P at 40/30 °C	kW	3.3 - 13.1	3.3 - 16.4	4.1 - 19.7	5.7 - 26.2	6.4 - 32.8	7.0 - 40.4	
Nominal heat output range P at 50/30 °C	kW	3.2 - 12.9	3.2 - 16.1	4.1 - 19.3	5.6 - 25.7	6.2 - 32.1	6.9 - 39.6	
Nominal heat output range P at 60/40 °C	kW	3.1 - 12.5	3.1 - 15.7	3.9 - 18.8	5.5 - 24.9	6.1 - 31.2	6.7 - 38.5	
Nominal heat output range P at 80/60 °C	kW	3.0 - 12.0	3.0 - 15.0	3.8 - 18.0	5.2 - 24.0	5.8 - 30.0	6.4 - 37.0	
Hot water output	kW	12.0	15.0	18.0	24.0	30.0	37.0	
Maximum thermal load for heating drinking water	kW	12.4	15.5	18.6	24.7	30.9	38.1	
Maximum thermal load on heating-side	kW	12.4	15.5	18.6	24.7	30.9	38.1	
Minimum thermal load	kW	3.1	3.1	3.9	5.4	6.0	6.6	
Heating output setting range	kW	3 - 12	3 - 15	4 - 18	5 - 24	6 - 30	6 - 37	
Heating								
max. flow temperature	°C	85						
Setting range max. flow temperature (factory setting: 75 °C)	°C	30 - 80						
permissible total over-pressure	bar	3.0						
Circulation water volume (with reference to $\Delta T = 20$ K)	l/min	516	645	774	1032	1290	1591	
Condensate volume approx. (pH value 3.5- 4.0) in heating mode 50 °C supply/30 °C return	l/h	1.2	1.6	1.9	2.5	3.1	3.8	
Residual feed head pump (at nominal circulation water volume)	mbar	250			200			
Electrical power consumption at 30% part load	W	40	40	45	50	50	50	
Hot water handling (only VUW)								
Least water volume	l/min	1.5						
Water volume (at $\Delta T = 35$ K)	l/min	4.9	6.1	7.4	9.8	12.3	15.2	
Water volume (at $\Delta T = 30$ K)	l/min	5.7	7.2	8.6	11.5	14.3	17.7	
Permitted overpressure	bar	10.0						
Required connection pressure	bar	0.35						
Hot water discharge temperature range	°C	35 - 65						
General								
Unit gas connection	Inches	G 1/2						
Unit heating connection	Inches	G 3/4						
Unit cold and hot water connection	Inches	G 3/4						
Exhaust gas connecting pieces	mm	60/100 (concentric), optional 80/125 (concentric)						
Gas connection pressure (gas flow pressure) natural gas, G20	mbar	20						
Gas connection pressure (gas flow pressure) propane, G31	mbar	37						
Connection value at 15 °C and 1013 mbar (based on hot water production if necessary)	G20 G31	m ³ /h kg/h	1.3 0.96	1.6 1.2	2.0 1.44	2.6 1.92	3.3 2.4	4.0 2.96
Exhaust gas mass flow min./max.	g/s	1.4/5.6	1.4/7.0	1.8/8.4	2.4/11.1	2.7/13.9	3.0/17.1	
Flue gas temperature min./max.	°C	40/70						
Exhaust gas connection approval		C13, C33, C43, C53, C63, C83, C93, B53						
Standard utilisation rate based on nominal heat output (in accordance with DIN 4702, Part 8) based on Hi (heating value)								
at 75/60 °C	%	107						
at 40/30 °C	%	109						
Standard utilisation rate based on nominal heat output (in accordance with DIN 4702, Part 8) based on Hs (calorific value)								
at 75/60 °C	%	96.4						
at 40/30 °C	%	98.2						
30% efficiency	%	108						
NOx class		5						
Unit dimensions (H x W x D)	mm	720 x 440 x 335				720 x 440 x 369	720 x 440 x 403	
Installation weight approx.	kg	35	35	35	37	39	41	

Tab. 16.1 Technical data ecoTEC plus VU
(continued on next page)

10 Technical data

ecoTEC plus	Unit	VU GB 126/5-5	VU GB 156/5-5	VU GB 186/5-5	VU GB 246/5-5	VU GB 306/5-5	VU GB 376/5-5
Electric connection	V/Hz	230/50					
Built-in fuse		2 A, slow-blow					
Minimum electrical power consumption	W	40	40	45	50	50	50
Maximum electrical power consumption	W	90	90	90	95	95	110
type of protection		IP X4 D					
Quality mark/certification number							

**Tab. 16.1 Technical data ecoTEC plus VU
(continued)**

ecoTEC plus	Unit	VUW GB 246/5-5	VUW GB 316/5-5	VUW GB 376/5-5	VUI GB 376/5-5	
Nominal heat output range P at 40/30 °C	kW	4.1 - 20.8	5.7 - 26.2	7.0 - 30.6	7.0 - 30.6	
Nominal heat output range P at 50/30 °C	kW	4.1 - 20.4	5.6 - 25.7	6.9 - 30.1	6.9 - 30.1	
Nominal heat output range P at 60/40 °C	kW	3.9 - 19.8	5.5 - 24.9	6.7 - 29.2	6.7 - 29.2	
Nominal heat output range P at 80/60 °C	kW	3.8 - 19.0	5.2 - 24.0	6.4 - 28.0	6.4 - 28.0	
Hot water output	kW	24.0	30.3	38.0	38.0	
Maximum thermal load for heating drinking water	kW	24.7	31.2	39.2	39.2	
Maximum thermal load on heating-side	kW	19.6	24.7	28.9	28.9	
Minimum thermal load	kW	3.9	5.4	6.6	6.6	
Heating output setting range	kW	4 - 19	5 - 24	6 - 28	6 - 28	
Heating						
max. flow temperature	°C	85				
Setting range max. flow temperature (factory setting: 75 °C)	°C	30 - 80				
permissible total over-pressure	bar	3.0				
Circulation water volume (with reference to $\Delta T = 20$ K)	l/min	817	1032	1204	1204	
Condensate volume approx. (pH value 3.5- 4.0) in heating mode 50 °C supply/30 °C return	l/h	2.0	2.5	2.9	2.9	
Residual feed head pump (at nominal circulation water volume)	mbar	250		200		
Electrical power consumption at 30% part load	W	45	50	50	50	
Hot water handling (only VUW)						
Least water volume	l/min	1.5				
Water volume (at $\Delta T = 35$ K)	l/min	9.8	12.4	15.6	15.6	
Water volume (at $\Delta T = 30$ K)	l/min	11.5	14.5	18.2	18.2	
Permitted overpressure	bar	10.0				
Required connection pressure	bar	0.35				
Hot water discharge temperature range	°C	35 - 65				
General						
Unit gas connection	Inches	G 1/2				
Unit heating connection	Inches	G 3/4				
Unit cold and hot water connection	Inches	G 3/4				
Exhaust gas connecting pieces	mm	60/100 (concentric), optional 80/125 (concentric)				
Gas connection pressure (gas flow pressure) natural gas, G20	mbar	20				
Gas connection pressure (gas flow pressure) propane, G31	mbar	37				
Connection value at 15 °C and 1013 mbar (based on hot water production if necessary)	G20 G31	m ³ /h kg/h	2.6 1.924	3.3 2.42	4.1 3.05	4.1 3.05
Exhaust gas mass flow min./max.	g/s	1.8/11.1	2.4/14.0	3.0/17.6	3.0/17.6	
Flue gas temperature min./max.	°C	40/70				
Exhaust gas connection approval		C13, C33, C43, C53, C63, C83, C93, B53				
Standard utilisation rate based on nominal heat output (in accordance with DIN 4702, Part 8) based on Hi (heating value)						
	at 75/60 °C	%	107			
	at 40/30 °C	%	109			
Standard utilisation rate based on nominal heat output (in accordance with DIN 4702, Part 8) based on Hs (calorific value)						
	at 75/60 °C	%	96.4			
	at 40/30 °C	%	98.2			
30% efficiency	%	108				
NOx class		5				
Unit dimensions (H x W x D)	mm	720 x 440 x 335		720 x 440 x 369	720 x 440 x 403	
Installation weight approx.	kg	36	38	41	43	

Tab. 16.2 Technical data ecoTEC plus VUW/VUI
(continued on next page)

10 Technical data

ecoTEC plus	Unit	VUW GB 246/5-5	VUW GB 316/5-5	VUW GB 376/5-5	VUI GB 376/5-5
Electric connection	V/Hz	230/50			
Built-in fuse		2 A, slow-blow			
Minimum electrical power consumption	W	45	50	50	50
Maximum electrical power consumption	W	90	95	110	110
type of protection		IP X4 D			
Quality mark/certification number					

Tab. 16.2 Technical data ecoTEC plus VUW/VUI
(continued)

Glossary

Air/exhaust gas pipework

The air/exhaust gas pipework consists of all components that route combustion air to the boiler or exhaust gas from the boiler.

Burner

The burner on a condensing boiler is the component in which the gas/air mix is control-burnt.

Calorific value

Unlike the heating value, the calorific value of a fuel describes the total useable heat during combustion, based on the quantity of fuel used, including the condensation heat in the steam. Condensing boilers use this additional condensation heat to achieve much high efficiency levels than conventional boilers.

Controller

The controller is the interface to the boiler and can be used to adjust the room temperature, hot water temperature, heating times or night-time temperature reduction.

A distinction is made between room thermostat, weather compensator and solar controller.

Cylinder charging

Cylinder charging refers to the process for heating up the cylinder.

See also hot water production.

Dew point

The dew point is the temperature at which steam turns to liquid (condensation). The steam in the exhaust fumes from the boiler contains thermal energy, which can be released by condensation. In gas-fired and oil-fired boilers using calorific values, the exhaust gases are cooled so that the steam condenses and the heat that it contains can be output into the heating system.

eBUS

The abbreviation eBUS is short for energyBUS.

The eBUS is a special cable system used in the heating technology field, which is used for communication between the heating technology components (e.g. controller, boiler, vrnetDIALOG).

Frost protection

The frost protection function protects your heating system and apartment from frost damage. If the heating flow temperature falls below 5 °C when the main switch is on, the boiler comes into operation and heats the heat generation circuit to approx. 30 °C.

Heating flow temperature

Your boiler heats water which is pumped through your heating system. The temperature of this hot water as it leaves the boiler is referred to as the heating flow temperature.

Hot water production VU units

Your boiler heats the water in the domestic hot water cylinder to the selected target temperature. If the temperature in the DHW cylinder falls by specific amount, the water is heated up again to the target temperature.

Hot water production VUW units

The hot water is supplied directly from the VUW unit. Comfort mode immediately supplies you with hot water at the required temperature, without you having to wait for the water to heat up. For this, the hot water heat exchanger is kept at a preselected temperature level.

Room thermostat

A room thermostat continuously measures the room temperature and compares it with the room temperature you have set (target room temperature). This allows the heating system to maintain a constant set temperature in your room.

In addition, you can enter individual heating times. The target room temperature and the heating times set by you control the operation of your boiler, the power of which is adapted automatically to the respective heat demand.

Weather compensator

A weather compensator is a controller that controls the heating flow temperature of the heating system as a function of the measured outside temperature.

On the weather compensator you can also enter individual heating times. The outside temperatures measured and the heating times set control the operation of the burner, the output of which is adjusted automatically to the respective heat demand.

vrnetDIALOG Internet communication system

vrnetDIALOG is a service connection to the Internet. Using vrnetDIALOG your approved heating engineer can set the heating system in your house from your PC. Fault diagnosis is also possible remotely via the integrated DIA system.

vrnetDIALOG can also forward fault messages by fax, E-mail or SMS to your heating engineer. This allows the heating engineer to prepare in advance of carrying out any work, if a repair is required, and to arrive with the right spare parts on the service date.

If necessary, your heating engineer can also carry out adjustments on the controller or boiler via vrnetDIALOG to save unnecessary visits.

Index

A		L	
Air/exhaust gas pipework	4, 25, 32	Legionella protection function.....	16
B		M	
Burner blocking time	10	Malfunction	23, 24, 25
C		Must be reported	22
CE label	3	O	
Control elements	9	Operating mode	20
Customer service.....	5, 26	S	
D		Setting	
Display	10, 11, 13, 18, 23	Setting the hot water temperature (VUW unit) ..	14, 17
Disposal.....	26	Setting storage tank charging (VUW unit)	16
E		Status displays	22
Energy saving tips	20	Summer mode	18, 20, 22
Exhaust fumes.....	5	Switching off	
F		Boiler.....	18
Fault	25	Hot water production.....	18
Fault codes	23	Switching off the boiler.....	18
Fault resolution	24	Switching on	
Filling	12	Boiler.....	11
Filling the heating system	12	Electricity supply	23
Fill pressure.....	12	Frost protection function.....	19
Flue gas.....	5, 8	Setting storage tank charging (VUW unit)	16
Frost		Switching on the boiler	11
Activating the frost protection function.....	19	Symbols.....	3
Draining the heating system.....	19	Symbols used.....	3
Protecting the heating system against frost	19	T	
G		Taking out of service.....	26
General safety instructions.....	5	Technical data.....	27
H		Temperature	
Heating flow temperature	13, 14	Setting the hot water temperature	14, 17
Hot water		Setting the hot water temperature (VUW unit) ..	14, 17
Drawing hot water	8	Troubleshooting	22
Setting cylinder charging (VUW unit).....	16	V	
Setting the hot water temperature	14, 17	Vaillant customer service	5, 26
Setting the temperature (VUW unit).....	14, 17	W	
Hot water production.....	4, 8, 11, 18, 20, 32	Water shortage.....	24
Hot water temperature.....	5, 8, 14, 17, 20		
I			
Identification plate	3		
If you smell gas	5		
Ignition	22, 24		
Intended use	4		
Isolator devices	11		

Supplier

Vaillant Ltd

Vaillant House ■ Medway City Estate ■ Trident Close ■ Rochester ■ Kent ME2 4EZ
Telephone 01634 292300 ■ Fax 01634 290166 ■ www.vaillant.co.uk ■ info@vaillant.co.uk

Manufacturer

Vaillant GmbH

Berghauser Str. 40 ■ D-42859 Remscheid ■ Telefon 0 21 91/18-0
Telefax 0 21 91/18-28 10 ■ www.vaillant.de ■ info@vaillant.de